

74511 - MANUAL for MUDBOX

PRODUCT INFORMATION

Product name:	Mudbox
Nominal size:	DN40-300
Nominal pressure:	PN4
Material (Body):	EN-JL1040 (GG25)
Material (Bonnet):	EN-JS1040 (GG25)
Material (Strainer):	Stainless steel 1.4432 (AISI326L)
Material (O-ring):	NBR

APPLICATION

Mudboxes are used in systems which needs to be protected against debris during pipe installation or regular operation. It is possible to get the strainer basket with 3, 5 or 8mm mesh size. Straight with PN 10 drilled flange ends. DN 200-300 with support feet. Suitable for fuel oil, lubrication oil, flammable hydraulic oil, seawater and freshwater. Variants exists with other material compositions and strainer mesh size.

OPERATING INSTRUCTIONS

The mudboxes has the nominal pressure rating PN4 but its connections are dimensioned according to PN10.

The strainer is designed with an inlet hole in its mesh. If flow enters from the opposite direction, dirt and other debris won't pass into the strainer and will eventually clog the inlet (see figure 5).

Angled mudboxes and strainers is designed with the inlet hole in the bottom. Flow should enter the mudbox from below and exit horizontally (see figure 6). If installed for flow to enter horizontally and exit downwards, debris will gather on the strainer floor and clog the outlet of the mudbox (see figure 7).

The mudbox is designed so that the strainer only can be mounted according to the flow direction of the mudbox (see figure 1 and 2). The flow direction of the mudbox is displayed with an arrow on the mudboxes body (see figure 3).

Placement of the mudbox should be done in a position where there is enough space to open and lift out the strainer for cleaning. For dimensions and lifting heights please see correct datasheet.

When opening the mudbox for cleaning or replacing the strainer, the flow through the mudbox must be turned off. Empty the mudbox on water with the plug in the bottom before pulling up the strainer to prevent unwanted water spill.

A mudbox will act as a flow resistance. Make sure to choose mudbox and strainer mesh size that can sustain a sufficient flowrate.

For more detailed information, please visit the Meson webpage or contact our company.

INSTALLATION INSTRUCTIONS

- Remove protecting covers from mudbox flanges.
- Protect the mudbox during the whole installation process.
- Make sure marking arrow on mudbox align with system flow direction.
- Use only counter flanges and screws that match those of the mudbox for the installation.
- Lifting of the mudbox is to be carried out by suitable handling equipment.
- Mudbox should be installed with bonnet pointing upwards.

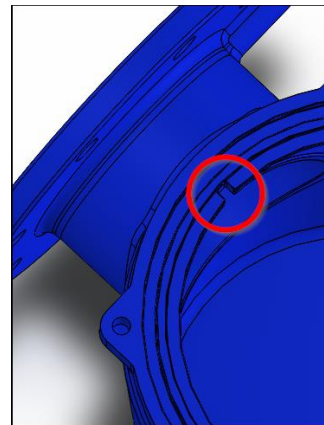

Figure 1 How to fit strainer.

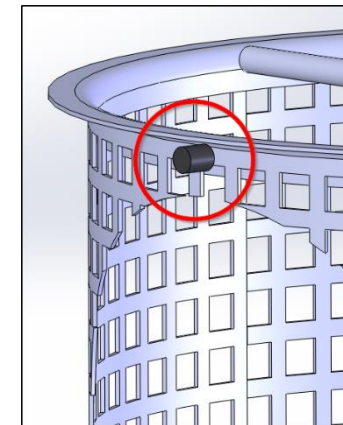

Figure 2 How to fit strainer.



Figure 7 Arrow displays flow direction.

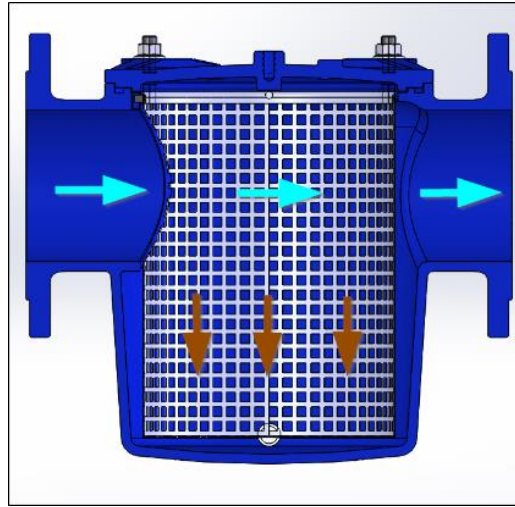

Figure 5 Mudbox installed correct. Dirt and other debris will fill the inside of the strainer.

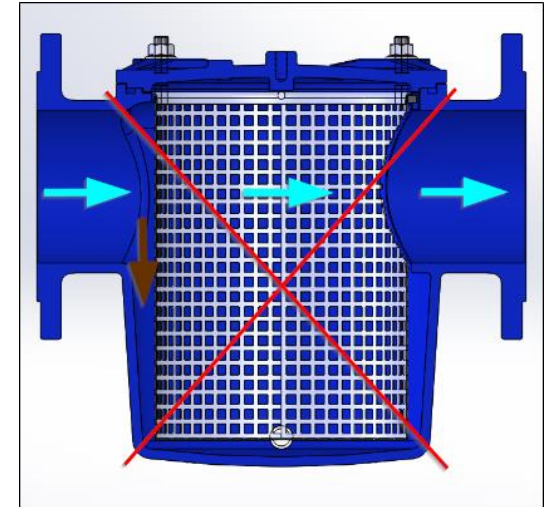

Figure 6 Mudbox installed incorrect. Dirt and other debris will not pass the strainer and will instead clog the inlet.

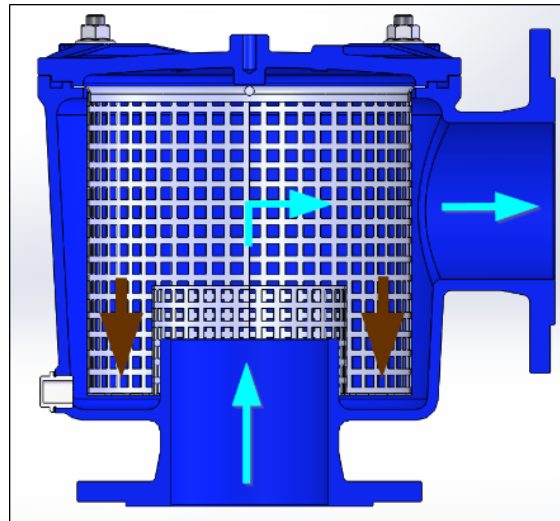

Figure 4 Mudbox installed correct. Dirt and other debris are accumulated in the bottom.

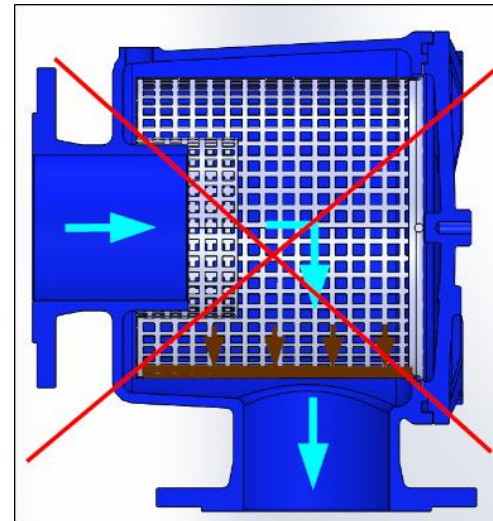

Figure 3 Flow exiting downwards as dirt and other debris clog the outlet.